

ANALYTIC SYSTEMS

Power Conversion Solutions

INSTALLATION & OPERATION MANUAL

BCA310 SERIES AC Battery Charger



An ISO9001 and AS9100 Registered Company Battery Chargers • Inverters • Power Supplies • Voltage Converters

8128 River Way, Delta B.C. V4G 1K5 Canada T. 604.946.9981 F. 604.946.9983 TF. 800.668.3884 (US/CANADA)

www.analyticsystems.com



ANALYTIC SYSTEMS
Power Conversion Solutions

Copyright (2005-2016) Analytic Systems Ware (1993) Ltd.



IMPORTANT & SAFETY INSTRUCTIONS

SAVE THESE INSTRUCTIONS — This manual contains important safety and operating instructions for the battery charger.

ALL BATTERY CHARGERS

1. **CAUTION** — To reduce risk of injury, charge only lead acid or sealed gel cell type rechargeable batteries. Other types of batteries may burst causing personal injury and damage.
2. Do not expose battery charger to rain or snow.
3. Use of an attachment not recommended or sold by the battery charger manufacturer may result in a risk of fire, electric shock, or injury to persons.
4. Do not disassemble battery charger; take it to a qualified serviceman when service or repair is required. Incorrect reassembly may result in a risk of electric shock or fire.
5. To reduce risk of electric shock, disconnect battery charger from batteries and AC supply before attempting any maintenance or cleaning. Turning off controls will not reduce this risk.

AC BATTERY CHARGERS

1. **WARNING** — RISK OF EXPLOSIVE GASES.
 - i. **WORKING IN VICINITY OF A LEAD-ACID BATTERY IS DANGEROUS. BATTERIES GENERATE EXPLOSIVE GASES DURING NORMAL BATTERY OPERATION. FOR THIS REASON, IT IS OF UTMOST IMPORTANCE THAT EACH TIME BEFORE SERVICING EQUIPMENT IN THE VICINITY OF THE BATTERY, YOU READ THIS MANUAL AND FOLLOW THE INSTRUCTIONS EXACTLY.**
 - ii. To reduce risk of battery explosion, follow these instructions and those published by battery manufacturer and manufacturer of any equipment you intend to use in vicinity of battery. Review cautionary marking on these products and on engine.
2. **PERSONAL PRECAUTIONS**
 - i. Someone should be within range of your voice or close enough to come to your aid when you work near a lead-acid battery.
 - ii. Have plenty of fresh water and soap nearby in case battery acid contacts skin, clothing, or eyes.
 - iii. Wear complete eye protection and clothing protection. Avoid touching eyes while working near battery.
 - iv. If battery acid contacts skin or clothing, wash immediately with soap and water. If acid enters eye, immediately flood eye with running cold water for at least 10 minutes and get medical attention immediately.



- v. NEVER smoke or allow a spark or flame in vicinity of battery or engine.
- vi. Be extra cautious to reduce risk of dropping a metal tool onto battery. It might spark or short-circuit battery or other electrical part that may cause explosion.
- vii. Remove personal metal items such as rings, bracelets, necklaces, and watches when working with a lead-acid battery. A lead-acid battery can produce a short-circuit current high enough to weld a ring or the like to metal, causing a severe burn.
- viii. NEVER charge a frozen battery.
- ix. If necessary to remove battery from service, always remove grounded terminal from battery first. Make sure all accessories are off, so as not to cause an arc.
- x. Be sure area around battery is well ventilated.
- xi. Clean battery terminals. Be careful to keep corrosion from coming in contact with eyes.
- xii. Study all battery manufacturer's specific precautions such as removing or not removing cell caps while charging and recommended rates of charge.
- xiii. Add distilled water in each cell until battery acid reaches level specified by battery manufacturer. This helps purge excessive gas from cells. Do not overfill. For a battery without cell caps, carefully follow manufacturer's recharging instructions.

3. BATTERY CHARGER LOCATION

- i. Never place battery charger directly above battery; gases from battery will corrode and damage converter.
- ii. Never allow battery acid to drip on battery charger when reading gravity or filling battery.

4. O/P CONNECTION PRECAUTIONS

- i. Connect and disconnect DC output connections only after setting battery charger switch to off position.

GROUNDING AND AC POWER CORD CONNECTION INSTRUCTIONS — The plug must be plugged into an outlet that is properly installed and grounded in accordance with all local codes and ordinances.

DANGER — Never alter the AC cord or plug provided. If it will not fit the outlet, have the proper cord installed by a qualified electrician. Improper connection can result in a risk of an electric shock.

Analytic Systems does not recommend the use of the BCA310 Series Battery Chargers in life support applications where failure or malfunction of this product can be reasonably expected to cause failure of the life support device or to significantly affect its safety or effectiveness. Analytic Systems does not recommend the use of any of its products in direct patient care.



Examples of devices considered to be life support devices are neonatal oxygen analyzers, nerve stimulators (whether used for anesthesia, pain relief, or other purposes), autotransfusion devices, blood pumps, defibrillators, arrhythmia detectors and alarms, pacemakers, hemodialysis systems, peritoneal dialysis systems, neonatal ventilator incubators, ventilators for both adults and infants, anesthesia ventilators, and infusion pumps as well as any other devices designated as “critical” by the U.S. FDA.

Introduction

This all new single board design incorporates state of the art switchmode technology for unmatched efficiency and ultra-quiet operation. Multiple stages of filtering reduce radiated or conducted noise to very low levels. Extra features include adjustable output voltage, audible and visual indicators for low input voltage, low output voltage and over temperature. Safety features include reverse input protection, over-temperature shutdown, current limiting, and short circuit protection with automatic recovery, input undervoltage shutdown, reverse battery protection and output overvoltage crowbar. Optional features include a dry contact alarm relay output, and remote panel monitoring with On/Off control.

Features

In a DC UPS (Un-interruptible Power Supply) , the charger simultaneously powers the DC load as well as the battery. As long as the AC power to the charger is available and the charger is working normally, the charger will supply the DC load as well as charge / float the battery. In case the AC power fails or if the charger stops working, the battery will automatically power the DC load. As soon as the AC power to the charger is restored, the DC load will once again be fed by the charger and at the same time the battery will be recharged. CAUTION! Please ensure that the sum of the current drawn by the DC load and the current desired for charging the battery is less than the maximum current capacity of the charger. To use as a DC UPS, first switch off the DC load and connect it to the battery. Now connect the battery. Switch on the charger and then switch on the DC load.



Specifications

Input Voltages				
Nominal (ip)	110		220	
Actual (Vac)	90 - 130		180 - 260	
Frequency (Hz)	45 - 65			
Input Amps (max)	5.2		2.6	
Input Fuse (slow blow)	MDA-7		MDA-4	
Output Voltages				
Nominal (op)	12	24	32	48
Float (Vdc)	13.6 ± 0.05	27.2 ± 0.05	36.3 ± 0.05	54.4 ± 0.05
Absorption Voltage (Vdc)	14.4	28.8	38.4	57.6
Charging Amps	20	10	7.5	5A
Absorption to Float	3.0 Amps	1.5 Amps	1.13 Amps	0.75A
Battery Banks	1, 2 or 3			
Battery Size (Amp Hours)*	80 – 120	40 - 60	30 – 45	20-35
Output Adjust	± 1.0 Volts			
Output Fuses	AGC 25	AGC 15	AGC 10	AGC10
Output Crowbar	16.0 ± 0.5 V	32.0 ± 1.0 V	42.7 ± 1.3 V	63.5 ± 2.0V
Temperature Compensation Coefficient	-30mV / o C	-60mV / o C	-80mV / o C	-120mV / o C
General				
Efficiency	> 75 % @ maximum output			
Stages	2 or 3			
Temp. Range	-25 to +40o C @ maximum output			
Isolation	Input-Case & Input-Output 1500 VDC, Output-Case 500 VDC			
Length	9.6 in / 24.4 cm			
Width	8.2 in / 20.8 cm			
Height	3.5 in / 6.4 cm			
Clearance	1 Inch (2.5 cm) all around			
Material	Marine Grade Aluminum			
Finish	Black Powder Epoxy			
Fastenings	18-8 Stainless			
Weight	7.0 lb / 3.2 kg			
Safety	ABS 11-HS794404A-PDA			

* This is Analytic Systems' suggested range. Please consult your battery manufacturer for their recommendations.

* Specifications subjects to change without notice.

Designed and manufactured by: **ANALYTIC SYSTEMS WARE (1993) LTD.**

8128 River Way, Delta, BC V4G 1K5 p. 604.946.9981 f. 604.946.9983 tf. 800.668.3884 US/Canada
Canada

www.analyticsystems.com

analyticinfo@analyticsystems.com

Revised August 2014



Installation

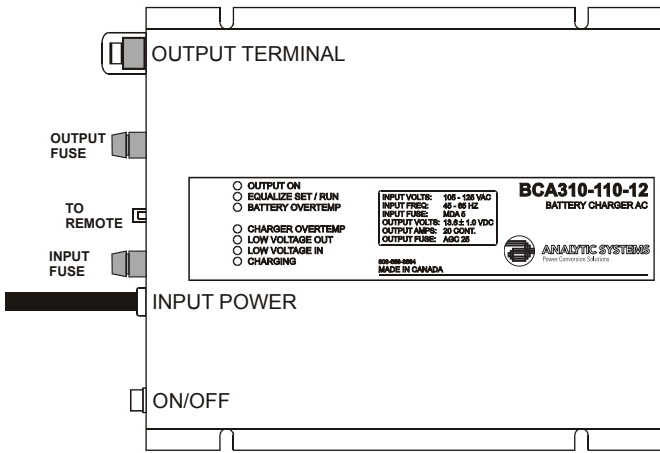

Allow at least 1 inch of clearance all around the case for cooling. The best mounting configuration is to mount the unit on a vertical surface oriented as shown. Use #10 screws of the appropriate type for the mounting surface to securely mount the unit.

There is 1500 volts of isolation between the input and output, and the input and case. There is 500 volts (1500V for 48V output units) of isolation between the output and case. Therefore, the unit may be mounted on any surface without fear of electrolysis or ground fault.

The unit is supplied with a 5 foot power cable. This should normally be adequate to connect to a source of power. If you must extend the power cable be sure to use a 3 conductor grounded type extension cable. For hard wiring to a source of power, cut off the plug, and strip the wires as necessary. The wire colors are

110 VAC	220 VAC
Brown - AC Hot	Brown - AC Hot / Phase 1
Blue - AC Neutral	Blue - AC Neutral / Phase 2
Green - Ground	Green/Yellow - Ground

All connections should be made inside an appropriate junction box. The maximum current draw from the 110 VAC supply is 3.5 amps, so a 5 amp circuit breaker should be used in the circuit panel. For a 220 VAC supply, 1.8 amps is the maximum current draw, so a 2.5 amp circuit breaker should be used in the circuit panel to feed power to the BCA 310.

To reduce radio noise to the absolute minimum, it may be necessary to bond the case to ground. To do this, remove one the screws that mount the output terminal strip to the chassis. Then place a #6 ring terminal with a ground wire crimped to it under the screw head, and replace the screw.



To ensure spark free connections the power switch must be in the OFF position prior to making the connections to the battery bank(s).

The unit may be hooked to 1, 2 or 3 battery banks. If you are hooking up 2 or 3 battery banks keep in mind that they MUST share a common ground! If you are hooking up 3 battery banks, hook them up as is shown below.

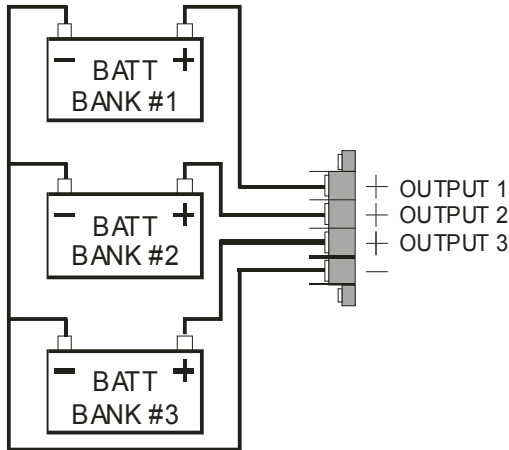

Operation

Prior to turning on the unit, you must decide on which charging profile, 2 or 3 stage charging, to use. To help you decide, please see the following section entitled 2 or 3 Stage Charging to determine the charging profile.

Once you have decided on the charging profile you must set the switch to the correct position. The switch is located to the right of the output terminal on the front panel. Set the switch to the correct position as shown on the label.

To turn the unit on, simply move the power switch to the ON position. The alarm buzzer will sound and the Low Output LED will come on briefly, and then the green OUTPUT ON LED will illuminate.

When the unit is first turned on, it will charge the batteries at maximum current and the charging light will be on. After a period of time which may be minutes to hours, the batteries will reach the absorption voltage (3-stage) or float voltage (2-stage), and the charging current will reduce as necessary to maintain the batteries at that voltage. Once the charging current has dropped to a low level (about 10% of the charging current rating), the charging light will go off, and if set to 3-stage charging the voltage will drop to the float level. You may check this voltage at the output terminals of the unit with a good digital voltmeter. As shipped from the factory, the unit is preset for a float voltage of 13.6, 27.2 or 36.3 VDC, which is generally



recommended for lead-acid batteries. The output adjust potentiometer is located to the right of the 2 stage / 3 stage select switch. If you wish to adjust this voltage, reach in with a very small flat blade screwdriver to rotate the potentiometer. Please Note that this adjusts both the float and absorption voltages at the same time. Clockwise increases the output voltage, and counter clockwise decreases it. It is advisable to check with the battery manufacturer before changing the float voltage.

2 or 3 Stage Charging

This charger features user selectable 2 or 3 stage charging. The charging profile is selected by moving the slide switch on the front panel up to 3 stage or down for 2 stage charging.

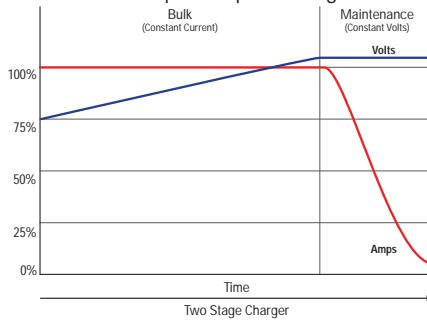

A two-stage charger provides a constant current until the battery reaches its rated capacity and then switches to a “float” voltage. The current then reduces as necessary to maintain the battery at the float voltage. The charger can be connected to the battery indefinitely and will provide the appropriate profile. A two-stage charger is recommended in most instances since it is the most versatile and can be permanently connected to attenuate the characteristic discharge of unused batteries. A load can be put on the battery or batteries without altering its ability to keep the battery at optimal charge.

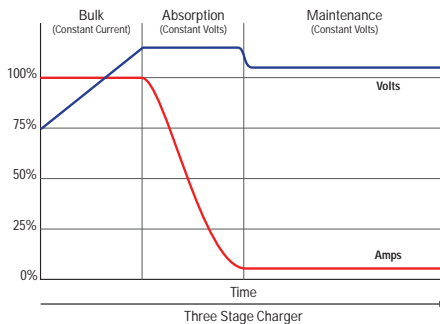

A three-stage charger is the fastest charger. It charges the battery at a constant current until the battery voltage reaches a slightly elevated level. The battery is maintained at this voltage while the charging current diminishes to a low value, and then the battery is switched to the float voltage where it can be maintained indefinitely. However, the charger cannot differentiate between a current going to a load on the battery, or being absorbed by the battery, so it can overcharge a battery supplying current to a load. A two-stage charger is preferred for “loaded” batteries and a three-stage for idle or unloaded batteries during recharging.



Troubleshooting

If the red **OVERTEMP LED** and the audible alarm come on, the unit has overheated, and it will shut down until it cools off sufficiently. You may not have allowed sufficient space around the unit for cooling, or there may be too many devices connected to the output of the unit. Either reduce the number of devices connected to the unit, or reposition the unit for better cooling. If necessary, direct a stream of moving air over the unit.

If the yellow **LOW INPUT LED** and the audible alarm comes on, the input voltage has dropped to below a usable level.

If the **LOW OUTPUT LED** and the audible alarm come on, and the green **OUTPUT ON LED** is completely off, the output of the unit has been shorted out, or there has been an internal failure. Turn the unit off, disconnect all the loads connected to it, and turn it back on again. If it comes on normally, turn it off again, reconnect one load, and turn it back on. Continue reconnecting loads until the short circuit condition returns. Turn the unit off, disconnect the faulty load, and reconnect it only after the fault is found and rectified. If the condition still exists even after all the loads have been disconnected, the unit is defective, and must be returned to the factory or an authorized service center for repair.

If the unit will not turn on at all, check the input fuse. To do this, first turn off the unit and disconnect the power cord. Next, remove the negative battery lead and cover the end with non conductive material such as tape. Repeat this with the other battery lead. This will prevent an accidental discharge from the battery. Remove the fuse and check it with an ohmmeter. If it is blown, replace it with a new one. If that fuse blows as well or the unit still will not turn on, it is defective, and must be returned to the factory or an authorized service center for repair.

If the batteries are hooked up backwards the output fuses will blow. To change them follow the same procedure as for the input fuse.

If both the input and output fuses are good and the unit still does not function it must be returned to the factory for servicing.

Meters

A high quality digital meter can be added to the voltage converter (factory installed only). The meter shows simultaneous voltage and current on either of the two output terminals. A toggle switch permits selection between the output terminals. The meter features bright red LED readouts to permit easy monitoring from many feet or meters away.



Dry Contact Relay

The charger is fitted with a dry contact relay to indicate output failure to a monitoring system. To use the dry contact output fail relay you must connect a 9-pin D connector to the unit. You must use pins one and six as is indicated on the remote connector diagram.

The relay is factory preset to fail in the closed position when the low output LED and buzzer come on. If you wish to have the relay fail in the open position when the low output LED and buzzer come on, you must take the cover off the unit and move the jumper to the other position on J11. J11 is located next to the relay.

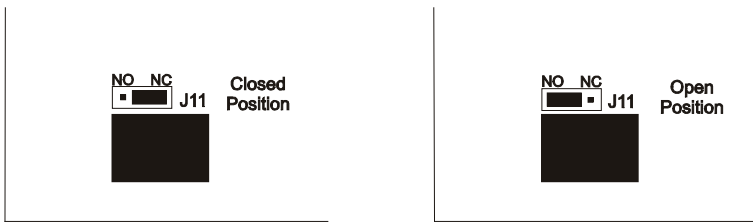

To change the position of the jumper, first turn the unit off and disconnect the unit from both the power and batteries. Next, turn the unit on for 30 seconds to discharge the capacitors, and then turn it off again. Turn the unit upside down and remove the four screws. Remove the base plate and locate J11. It will be next to the relay as is shown in the above diagram. Simply move the jumper to the desired position as is shown in the above diagram. Replace the base plate and re-install the four screws. Reconnect the unit to the power and batteries.

Field Conversion from 110Vac to 220Vac Operation

This unit may be converted from 110Vac operation to 220Vac operation. Please contact the dealer or manufacturer if you wish to convert your unit. (Attempting to do this conversion yourself, will void the warranty!)

BATTERY TEMPERATURE SENSORS

Up to 2 battery temperature sensors can be connected to the charger to allow temperature compensation of the battery charging voltage (1 is supplied with the unit). If only the 1 sensor is used, it **MUST** be plugged into the 'BATT 1' connection on the rear of the unit. If no sensor is used, the charger will default to standard output voltage.

For installation instructions of the temperature sensor, please see the section entitled Remote Battery Temperature Sensor Installation

Remote Control Option



IMPORTANT: This remote is to be used only on Battery Chargers manufactured by Analytic Systems.

A remote control panel may be connected to the inverter using a 9-pin D-connector, which attaches to the battery charger. The remote control panel and D connector are part of the remote control option. The remote control panel allows the unit to be operated remotely as well as duplicating all the diagnostic indicators and audible alarm.

REMOTE CONNECTOR

This connector is located on the side of the unit. Important: To prevent the possibility of High Voltage Electrical Shock, do not power up the battery charger unless all wiring from the unit to the remote is securely connected. Do not remove the dust cover from the DB-9 connector if the remote is not being used.

Equalize Option

The purpose of the Equalize Option is to deliberately overcharge the battery at a low rate of current to ensure that all cells are fully charged and to reduce the chance of sulfation. During the Equalize cycle, the cells, which are fully charged, will produce Hydrogen gas, and the cells, which are undercharged, will be brought up to full charge. An Equalize cycle should be done once every 2-3 months, or whenever battery capacity appears to be diminished. The Equalize Option also includes a battery temperature sensor to compensate the charging voltage for battery temperature, as well as to shut the charger down if the battery should become overheated. A 2nd temperature sensor can be added to allow monitoring of both batteries if the charger is connected to 2 banks of batteries.

An Equalize cycle can be initiated at any time by simply pressing the equalize start button located in the hole labeled EQ SEL. This button is deliberately recessed to prevent accidental operation. It is most easily pressed by using a ballpoint pen. If the charger is in the middle of charging the battery (the Charging LED is on), the Equalize LED will flash. Once the main charging cycle is complete, the Equalize cycle will begin and the Equalize LED will stay on all the time. If the Charging LED is off when the button is pressed, the Equalize cycle will begin immediately.

The charger will charge the battery at approximately 10% its normal rate (i.e. 4 amps for a 40 amp charger) until the battery reaches a maximum voltage of 15.5 volts (31.0 volts for a 24V battery, etc.) and then reduce the current as necessary to maintain the battery at that voltage. Three hours after the Equalize cycle begins, the charger will return to the float mode where



the battery can be maintained indefinitely. If the battery temperature reaches 120 degrees F (50 degrees C) the equalize cycle will end and the charger output reduced to a very low voltage until the battery cools, and then the charger will return to the float mode.

Remote Battery Temperature Sensor Installation

The remote battery temperature sensor allows the monitoring of the battery bank so that the charging profile can be adjusted to optimally charge the battery bank depending on the temperature of the battery bank. NOTE: The temperature sensor must be used during an equalize cycle or damage to the battery may occur.

The battery temperature sensor may be installed in many different ways, so long as the sensor stays in contact with the battery. The preferred method is as follows:

The batteries to be charged will be placed on a platform made of wood. Prior to placing the batteries on the wooden platform a cavity is hollowed out such that the sensor will fit inside the cavity and be flush with the surface. Place the sensor inside the cavity facing the proper way (this is shown on the sensor). Plug the sensor into the connector marked 'TEMP' on the front of the charger. If only one battery sensor is used, it MUST be plugged into the 'BATT 1' location.

If a battery blanket is used the sensor may be tucked inside the blanket with the proper side of the sensor facing the battery. The sensor may be placed on top of the battery but it should be secured to the battery so as to prevent it from losing contact.

Battery Charger Temperature Compensation

The charger is calibrated with the sensor input preset to 77 degrees (25 degrees C). For example, for a 12V battery, this voltage is 13.6 volts, and 27.2 volts for a 24V battery. See the specifications for the temperature compensation coefficient.

Battery Over-temperature Shutdown

If the battery reaches a temperature greater than 120 degrees (49 degrees C) the BATTERY OVERTEMP LED will turn on, the audible alarm will sound and the charger will shut down. Note: This alarm will operate in both normal 2/3 stage charge mode and in Equalize mode.

To restart the unit the temperature of the battery needs to return to a normal operating range and the charger power



Page intentionally left blank



Limited Warranty

1. The equipment manufactured by Analytic Systems Ware (1993) Ltd. (the "Warrantor") is warranted to be free from defects in workmanship and materials under normal use and service.
2. This warranty is in effect for:
 - a. 3 Years from date of purchase by the end user for standard products offered in our catalog.
 - b. 2 Years from date of manufacture for non-standard or OEM products
 - c. 1 Year from date of manufacture for encapsulated products.
3. Analytic Systems will determine eligibility for warranty from the date of purchase shown on the warranty card when returned within 30 days, or
 - a. The date of shipment by Analytic Systems, or
 - b. The date of manufacture coded in the serial number, or
 - c. From a copy of the original purchase receipt showing the date of purchase by the user.
4. In case any part of the equipment proves to be defective, the Purchaser should do the following:
 - a. Prepare a written statement of the nature of the defect to the best of the Purchasers knowledge, and include the date of purchase, the place of purchase, and the Purchasers name, address and telephone number.
 - b. Call Analytic Systems at 800-668-3884 or 604-946-9981 and request a return material authorization number (RMA).
 - c. Return the defective part or unit along with the statement at the Purchasers expense to the Warrantor; Analytic Systems Ware (1993) Ltd., 8128 River Way, Delta, B.C., V4G 1K5, Canada.
5. If upon the Warrantor's examination the defect proves to be the result of defective material or workmanship, the equipment will be repaired or replaced at the Warrantor's option without charge, and returned to the Purchaser at the Warrantor's expense by the most economical means. Requests for a different method of return or special handling will incur additional charges and are the responsibility of the Purchaser.
6. Analytic Systems reserves the right to void the warranty if:
 - a. Labels, identification marks or serial numbers are removed or altered in any way.
 - b. Our invoice is unpaid.
 - c. The defect is the result of misuse, neglect, improper installation, environmental conditions, non-authorized repair, alteration or accident.
7. No refund of the purchase price will be granted to the Purchaser, unless the Warrantor is unable to remedy the defect after having a reasonable number of opportunities to do so.
8. Only the Warrantor shall perform warranty service. Any attempt to remedy the defect by anyone else shall render this warranty void.
9. There shall be no warranty for defects or damages caused by faulty installation or hook-up, abuse or misuse of the equipment including exposure to excessive heat, salt or fresh water spray, or water immersion except for equipment specifically stated to be waterproof.
10. No other express warranty is hereby given and there are no warranties that extend beyond those described herein. This warranty is expressly in lieu of any other expressed or implied warranties, including any implied warranty of merchantability, fitness for the ordinary purposes for which such goods are used, or fitness for a particular purpose, or any other obligations on the part of the Warrantor or its employees and representatives.
11. There shall be no responsibility or liability whatsoever on the part of the Warrantor or its employees and representatives for injury to any person or persons, or damage to property, or loss of income or profit, or any other consequential or resulting damage which may be claimed to have been incurred through the use or sale of the equipment, including any possible failure of malfunction of the equipment, or part thereof.
12. The Warrantor assumes no liability for incidental or consequential damages of any kind



ANALYTIC SYSTEMS

Power Conversion Solutions

An ISO9001 and AS9100 Registered Company Battery Chargers • Inverters • Power Supplies • Voltage Converters

8128 River Way, Delta B.C. V4G 1K5 Canada T. 604.946.9981 F. 604.946.9983 TF. 800.668.3884 (US/CANADA)

www.analyticsystems.com