



RB10

LITHIUM IRON PHOSPHATE BATTERY

ELECTRICAL SPECIFICATIONS

Nominal Voltage	12.8 V
Nominal Capacity	10 Ah
Capacity @ 25A	24 min
Energy	128 Wh
Resistance	90 m
Efficiency	99%
Self Discharge	<3% per Month
Maximum Modules in Series	1

DISCHARGE SPECIFICATIONS

Maximum Continuous Discharge Current	10 A
Peak Discharge Current	20 A (7.5 s ±2.5 s)
PCM Discharge Current Cut-0	30 A (±5 A)
Recommended Low Voltage Disconnect	11 V
PCM Discharge Voltage Cut-0	8 V
Reconnect Voltage	10 V
Short Circuit Protection	200-500 μs

TEMPERATURE SPECIFICATIONS

Discharge Temperature	-4 to 140 °F (-20 to 60 °C)
Charge Temperature	32 to 131 °F (0 to 55 °C)
Storage Temperature	-4 to 140 °F (-20 to 60 °C)
PCM High Temperature Cut-0	176 °F (80 °C)

DIMENSIONAL SPECIFICATIONS

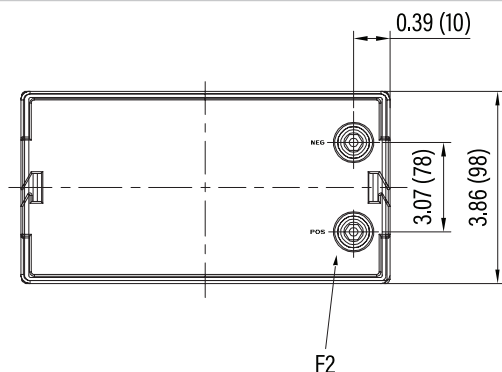

MECHANICAL SPECIFICATIONS

Dimensions (L x W x H)	5.9 x 3.9 x 4.0"
	151 x 98 x 101 mm
Weight	3.6 lbs (1.65 kg)
Terminal Type	F2
Case Material	ABS
Enclosure Protection	IP56
Cell Type	Cylindrical
Chemistry	LiFePO ₄

CHARGE SPECIFICATIONS

Recommended Charge Current	5 A
Maximum Charge Current	10 A
PCM Charge Current Cut-0	30 A (±5 A)
Recommended Charge Voltage	14.2 V - 14.6 V
PCM Charge Voltage Cut-0	15.6 V
Reconnect Voltage	15.2 V
Balancing Voltage	14.4 V

COMPLIANCE SPECIFICATIONS

Certifications	CE (battery) UN38.3 (battery) UL1642 & IEC62133 (cells)
Shipping Classification	UN 3480, CLASS 9

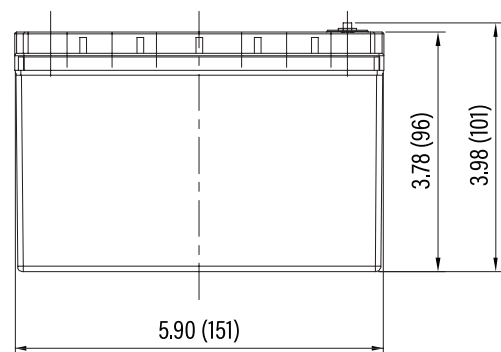



RB10

PERFORMANCE CHARACTERISTICS

