



RB20

LITHIUM IRON PHOSPHATE BATTERY

ELECTRICAL SPECIFICATIONS

Nominal Voltage	12.8 V
Nominal Capacity	20 Ah
Capacity @ 25A	48 min
Energy	256 Wh
Resistance	60 m
Efficiency	99%
Self Discharge	<3% per Month
Maximum Modules in Series	3

DISCHARGE SPECIFICATIONS

Maximum Continuous Discharge Current	20 A
Peak Discharge Current	40 A (7.5 s ±2.5 s)
PCM Discharge Current Cut-0	70 A (±10 A)
Recommended Low Voltage Disconnect	11 V
PCM Discharge Voltage Cut-0	8 V
Reconnect Voltage	10 V
Short Circuit Protection	200-500 µs

TEMPERATURE SPECIFICATIONS

Discharge Temperature	-4 to 140 °F (-20 to 60 °C)
Charge Temperature	32 to 131 °F (0 to 55 °C)
Storage Temperature	-4 to 140 °F (-20 to 60 °C)
PCM High Temperature Cut-0	176 °F (80 °C)

DIMENSIONAL SPECIFICATIONS

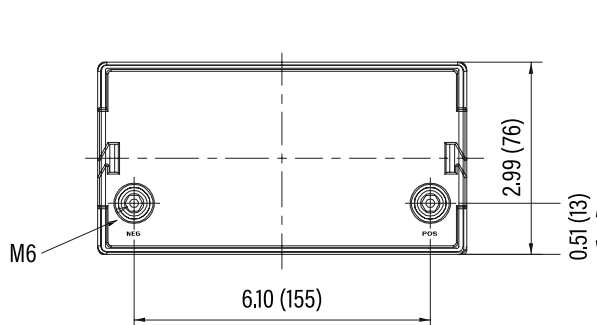

MECHANICAL SPECIFICATIONS

Dimensions (L x W x H)	7.1 x 3.0 x 6.7"
	181 x 76 x 169 mm
Weight	5.6 lbs (2.55 kg)
Terminal Type	M6
Terminal Torque	35 - 44 in-lbs (4 - 5 N-m)
Case Material	ABS
Enclosure Protection	IP56
Cell Type - Chemistry	Cylindrical - LiFePO ₄

CHARGE SPECIFICATIONS

Recommended Charge Current	10 A
Maximum Charge Current	20 A
PCM Charge Current Cut-0	70 A (±10 A)
Recommended Charge Voltage	14.2 V - 14.6 V
PCM Charge Voltage Cut-0	15.2 V
Reconnect Voltage	14.4 V
Balancing Voltage	14.4 V

COMPLIANCE SPECIFICATIONS

Certifications	CE (battery) UN38.3 (battery) UL1642 & IEC62133 (cells)
Shipping Classification	UN 3480, CLASS 9

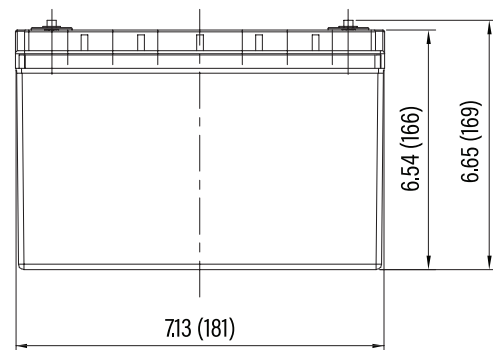



RB20

PERFORMANCE CHARACTERISTICS

