



PowerSafe® SBS 2 Volt



Telecommunications

NEBS™ Certified*

Battery Range Summary



EnerSys® outstanding EON Technology® further extends the technical leadership of PowerSafe® SBS® batteries: not only do PowerSafe® SBS EON Technology cells and monoblocs retain the benefits typically associated with EnerSys' Thin Plate Pure Lead Technology (long life, high energy density, superior shelf life, etc.), they also deliver exceptional cyclic performance in both float and fast charge applications, even in the hottest and harshest operating environments.

Where conventional VRLA AGM batteries struggle to cope with harsh conditions and frequent power outages, EON Technology makes PowerSafe SBS 2V batteries the perfect solution for the challenging operating conditions of today's telecommunication networks. The specification of PowerSafe SBS EON Technology also makes SBS 320 - 900 suitable for large-scale UPS and off-grid energy storage applications.

The PowerSafe SBS EON 2 Volt blocks are available in industry leading energy densities ranging from 320 - 900 Ah in top terminal configurations with a form factor matching DIN OPzV container sizes.

For superior energy and power, high performance and proven reliability, there is no substitute to PowerSafe SBS EON Technology batteries.

Features and Benefits

- Capacity range: 320 - 900Ah
- Superior cyclic performance
- Exceptional fast charge acceptance ability
- High energy density
- Resilient to harsh environments
- Long design life
- Up to two year shelf life

*Pending

Visit us at www.enersys.com

EnerSys®

Power/Full Solutions

RESERVE
POWER

Publication No: US-SBS2V-RS-001 - September 2014

Construction

- Concast positive grids
- Negative plates - provide perfect balance with the positive plates to ensure optimum recombination efficiency
- Separators - superior quality microporous glass mat separator with high absorption and stability
- Containers and lids - UL94 V-0 rated flame retardant ABS material, highly resistant to shock and vibration
- Electrolyte - high grade dilute sulphuric acid absorbed into separator material
- Terminal design - proven, high integrity leak resistant terminal seal design
- Self-regulating pressure relief valves - prevent ingress of atmospheric oxygen
- Flame arrestors - built into each cell for increased operational safety

Installation and Operation

- Designed for operation in traditional float applications and cyclic/hybrid applications
- PowerSafe® SBS® batteries are designed for use in cabinets or on racks, close to the point of use. A separate battery room is not required
- SBS EON Technology® models can be mounted in any orientation except inverted. In cyclic/hybrid applications, EnerSys® recommends to install SBS 320 - 900 cells in horizontal orientation
- Up to two year shelf life
- Low maintenance: no water addition required
- Wide operating temperature range: -40°F to 122°F (-40°C to +50°C)

Standards

- Designed to be compliant with international standard IEC 60896/21 & 22
- UL recognized component
- Approved as non-hazardous cargo for ground, sea and air transportation in accordance with US DOT Regulation 49 and ICAO & IATA Packing Instruction 872
- The management systems governing the manufacture of PowerSafe SBS products are ISO 9001:2008 and ISO 14001:2004 certified

General Specifications

Battery Type	Nominal Capacity (Ah)			Nominal Dimensions						Electrolyte (1.300 S.G.)				Pure Acid (H ₂ SO ₄) Acid								
	Nominal Voltage (V)	10hr. Rate 1.80Vpc @ 20°C	8hr. Rate 1.75Vpc @ 77°F	Length in	Length mm	Height in	Height mm	Depth in	Depth mm	Typical Weight Unpacked lbs	Typical Weight Unpacked kg	Terminal Type	Volume (per cell) gal	Volume (per cell) L	Weight (per cell) lbs	Weight (per cell) kg	Volume (per cell) gal	Volume (per cell) L	Weight (per cell) lbs	Weight (per cell) kg	Lead Weight (per cell) lbs	Lead Weight (per cell) kg
SBS 320	2	320	320	4.10	104	8.10	206	15.9	404	44.1	20.0	M10 F	0.79	2.99	8.56	3.88	0.22	0.84	3.39	1.54	29.1	13.2
SBS 400	2	400	400	4.90	124	8.10	206	15.9	404	52.9	24.0	M10 F	0.98	3.71	10.6	4.81	0.28	1.04	4.21	1.91	35.3	16.0
SBS 480	2	480	480	5.70	145	8.10	206	15.9	404	61.7	28.0	M10 F	1.16	4.39	12.6	5.70	0.33	1.24	4.98	2.26	41.1	18.6
SBS 580	2	580	580	4.90	124	8.10	206	20.5	521	72.8	33.0	M10 F	1.40	5.30	15.2	6.88	0.39	1.49	6.01	2.73	48.9	22.2
SBS 680	2	680	680	5.70	145	8.10	206	20.5	521	84.9	38.5	M10 F	1.66	6.28	18.0	8.16	0.47	1.77	7.13	3.23	57.0	25.9
SBS 780	2	780	780	6.50	165	8.10	206	20.5	521	97.0	44.0	M10 F	1.93	7.31	20.9	9.48	0.54	2.06	8.29	3.76	65.4	29.7
SBS 900	2	900	900	5.70	145	8.10	206	27.4	696	110	50.0	M10 F	2.19	8.29	23.7	10.8	0.62	2.33	9.41	4.27	73.9	33.5

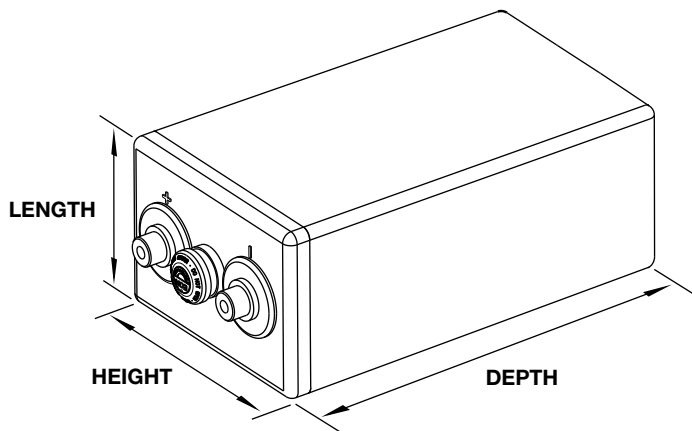

SBS 320 - 900

