

# CANTEC PRO SERIES 1500

HF / PFC BATTERY CHARGERS

## Description

- Advanced high frequency switching design with 92% typical efficiency
- Fully sealed enclosure provides improved reliability in demanding environments
- > 0.98 Power Factor minimizes utility surcharges and maximizes use of AC power
- Approved battery charge algorithms for ideal charging (default I1, I2, U, I3a)
- Memory to store 10 unique algorithms, and tools to load new algorithms in the field
- The internal CPU employs advanced charging management algorithm



## Technical Features

### DC Output

	24xx	36xx	48xx	60xx	72xx	96xx	120xx	144xx
DC Output Voltage - nominal	24V	36V	48V	60V	72V	96V	120V	144V
DC Output Voltage - maximum	34V	51V	68V	85V	102V	136V	170V	204V
DC Output Current - maximum	40A	30A	25A	20A	16A	12A	10A	8A
DC Output Current - at 115vac	40A	25A	20A	16A	13A	9.5A	8A	6.5A
Battery Type	Specific to selected algorithm							
Reverse Polarity	Electronic protection – auto-reset							
Short Circuit	Output closed automatically							

### AC Input

AC Input Voltage - range	90 - 260VAC
AC Input Voltage - nominal	120 VAC / 230 VAC
AC Input Frequency	45 - 65 Hz
AC Input Current - maximum	15A
Current – nominal	12.5 A rms @ 120 VAC / 6.5 A rms @ 230 VAC
AC Power Factor - nominal	> 0.98

### Mechanical

Dimensions	352mm×175mm×139mm
Weight	< 6.5kg Standard output cord
Environmental Enclosure:	IP46
Shock & Vibration Level:	SAEJ1378
Operating Temperature	-30°C to +50°C (-86°F to 122°F)
Storage Temperature	-40°C to +85°C (-104°F to 185°F)

## LED Indicator

<b>Red-Green flash (one second interval)</b>	Battery Disconnected
<b>Red flash (three seconds interval)</b>	Repair Battery
<b>Red flash (one second interval)</b>	<80% Charge Indicator
<b>Yellow flash (one second interval)</b>	>80% Charge Indicator
<b>Green flash (one second interval)</b>	100% Charge Indicator

## Protection Features

1. Thermal Self-Protection: When the internal temperature of the charger exceeds 80°C, the charging current will reduce automatically. If exceeds 85°C, the charger will shutdown protectively, there is no current output in this case. When the internal temperature drops to 80°C, it will resume charging automatically.
2. Short-circuit Protection: when the charger encounters unexpected short circuit across the output, charging will automatically stop. By cutting AC power for 10 seconds, the charger can be re-set and will start normally(with the output circuit corrected)
3. High and Low Voltage Protection: when the input AC Voltage is higher or lower than the rated input voltage range, the charger will shutdown protectively, but resume working after the voltage is normal again.

## Inter-lock Function

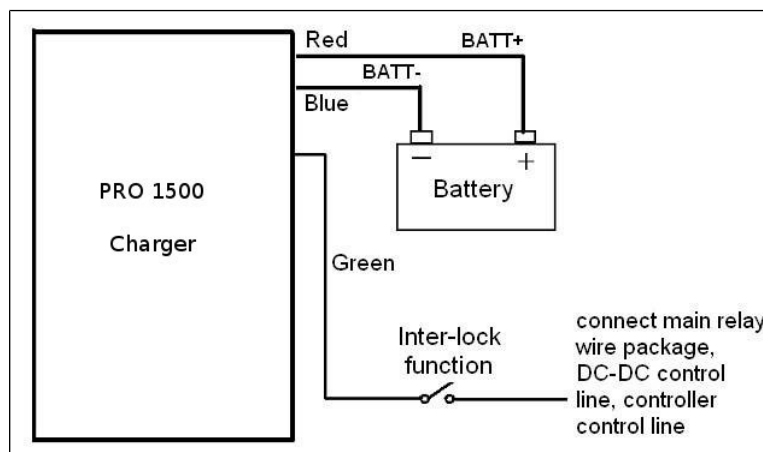

When it discharges, the internal electrical relay connects the blue and red wire, and outputs battery voltage. During the charging, the blue wire disconnects the internal connection, and no voltage outputs.

Note: Do not let the current on green wire flow over 2A

## Choice of Charging Curve (curve 1~10)

1. The LED will flash red several times when AC is first connected, then the LED will flash green once. The number of red flashes denotes the present curve. E.g. If the red flashes three times, it means the present curve is curve 3.
2. To choose another curve, please cut off the power supply first, then unpeel the label, pressing the button while connecting the power. If you want to choose curve 3, release the button after the 3rd LED Flash. Now the selected curve (e.g. curve 3) will be recorded in memory. If you want the charger to work with the selected curve (e.g. curve 3), cut off the power and reconnect it.

## Alarms

	LED Flashing Sequence ( One Cycle )	Indication
1	R G _ _ _ _ _	Wrong Battery
2	R G R _ _ _ _	Overcharged
3	R G R G _ _ _ _	The temperature of battery is too high
4	R G R G R _ _ _	Incorrect AC Input Voltage
5	R G R G R G _ _	The thermal sensor of charger is in fault
6	R G R G R G R _	The interface of communication is in fault
7	G R _ _ _ _ _	The temperature of charger is too high
8	G R G _ _ _ _	The relay of charger is in fault; Repair
9	G R G R _ _ _ _	Charger is in fault; Repair

### Note:

1. R—red G—green
2. “\_” denotes one second stop
3. Above LED flashing sequence is just one cycle, the LED will flash repeatedly when in fault

## Installation & Safety Instructions

Our charger has been designed to provide safety and reliability. It is important to observe the following precautions and installation instructions in order to avoid damage to persons and to the battery charger. For further reference keep the instruction in a proper place.

1. Fix the battery charger to a stable surface with the holes inserted on the mounting tabs. In case of installation on a vehicle, it is advisable to use anti-vibration supports.
2. Preferably the charger should be installed in the vertical position with radiator fins vertical. A space of 10cm above ground should be vacated, to ensure it is ventilated. Never install in the vertical position with fins facing down. Refer to drawing below:

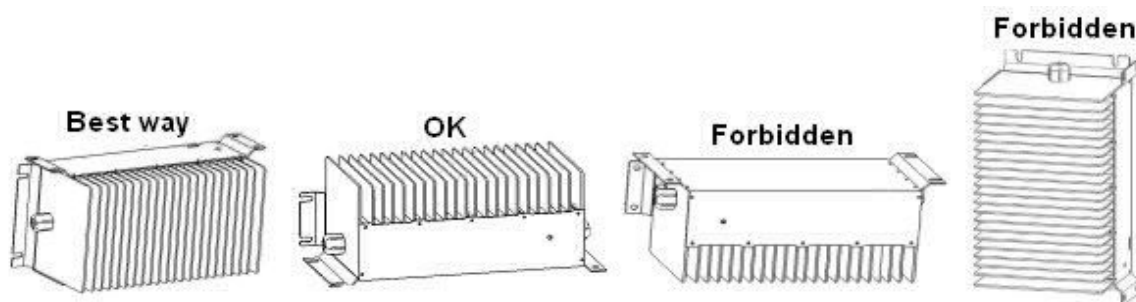

3. Ensure all heat dissipating parts are not obstructed to avoid overheating. Do not put the battery charger near any heat sources. Make sure that free space around the battery charger is sufficient to provide adequate ventilation and easy access to cable sockets.
4. For safety and electromagnetic compatibility the battery charger has a 3-prong plug that will only plug into a proper grounded outlet
5. To avoid damaging the power cord, do not put anything on it or place it where it will be walked on. If the cord becomes damaged or frayed, replace it immediately.
6. If you are using an extension cord or power strip, make sure that the total of the amperes required by all the equipment on the extension is less than the extension's rating.
7. Verify that the selected charging curve is suitable for the type of battery to be recharged.
8. In order to avoid voltage drop, the output cables must be as short as possible, and the diameter must be adequate for the output current.

9. Do not try to service the battery charger yourself. Opening the cover may expose you to shock or other hazards.
10. If the battery charger does not work correctly or if it has been damaged, unplugged it immediately from the supply socket, from the battery and contact a retailer.
11. In the case of thermal compensation for the battery voltage, it is necessary to place the thermal sensor in the area of the highest battery temperature, such as between 2 batteries near the center of the pack.

### Attentions

To reduce the risk of electric shock, do not remove cover. Refer servicing to qualified service personnel. Disconnect the mains supply before connecting or disconnecting the links to the battery. Read the instruction manual carefully before use. Verify that the selected charge curve is suitable for the type of battery you have to re-charge.

### Mechanical Dimensions

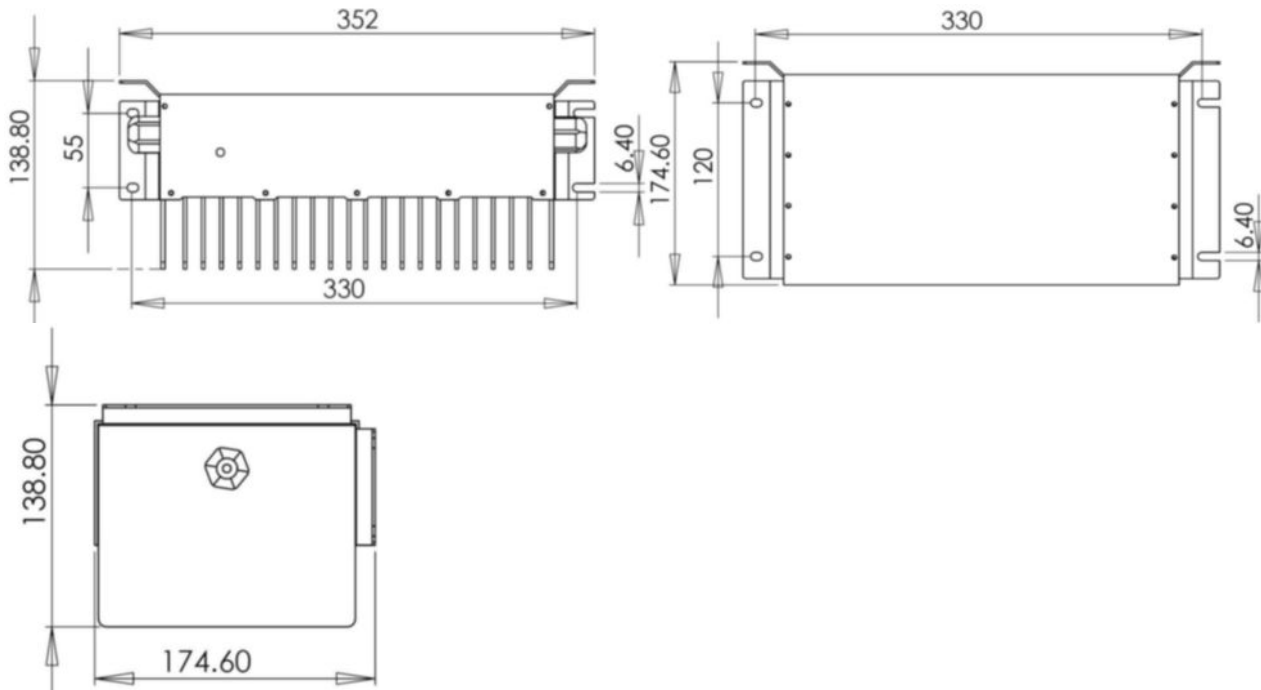

All dimensions are expressed in mm

**Cantec**  
Systems

**Your Power Solutions Specialists**

1573 LAPERRIERE AVENUE OTTAWA ON K1Z 7T3

OTTAWA  
Tel: 613-725-3704  
Fax: 613-725-0490

TORONTO:  
Tel: 613-725-3704  
Fax: 613-725-0490

VANCOUVER:  
Tel: 604-736-4922  
Fax: 604-736-1074

ADVISOR OF CANTEC REPRESENTATIVES